

Hand & power tools

Supporting:

***MSFFL2001: Use flooring
technology sector hand and power
tools***



Learner guide



INTAR Flooring Technology Project 2015

Hand and power tools Learner guide



This Learner guide is part of a suite of resources developed for learners undertaking the *Certificate III in Flooring Technology* (MSF30813). Its purpose is to help apprentice floor layers, sales staff and other workers to acquire the background knowledge needed to satisfy the theoretical components of the competencies covered. It is not designed to replace the practical training necessary to develop the hands-on skills required.

E-learning version

All of the content material contained in this Learner guide is also available in an e-learning format, which has additional photos, interactive exercises and a voice-over narration of the text. The e-learning version can be viewed on the web at: www.intar.com.au



ISBN: 978-1-925087-39-0

This training resource forms part of the **Flooring Technology project**, developed and coordinated by INTAR (Industry Network Training and Assessment Resources). To see the on-line versions of the resources available under this project, please go to the INTAR website and follow the links.



Copyright

The original version of this resource was developed by Workspace Training for INTAR members – with the copyright owned by McElvenny Ware Pty Ltd, trading as Workspace Training. Parts of the resource are based on material developed by Workspace Training with funding provided by the Workplace English Language and Literacy (WELL) Program – with copyright owned by the Commonwealth Government under a Creative Commons Attribution-Noncommercial-Share Alike 3.0 Australia Licence. All enquiries regarding copyright should be addressed to:

David McElvenny, Workspace Training, PO Box 1954 Strawberry Hills, NSW, 2012

Email: david@workspacetraining.com.au

Disclaimer

The content of this resource is provided for educational purposes only. No claim is made as to its accuracy or authenticity. The authors, copyright owners and INTAR do not give any warranty nor accept any liability in relation to the information presented in this work.

In all cases, users should consult the original source documents before relying on any information presented in the resource. These source documents include manufacturers' installation guides, Australian Standards, codes of practice and other materials produced by specialist industry bodies and government agencies.

Acknowledgements

The INTAR project team comprises the following people: David McElvenny (Workspace Training) – lead writer and project manager; Kath Ware (Workspace Training) – instructional designer and graphic artist, Jim Vaughan (VCSS) – technical developer and programmer; Alex Vaughan (VCSS) – assistant programmer and voice-over narrator.

All line drawn graphics were produced by Kath Ware. Many of these graphics are based on line drawings or photographs from installation manuals published by floor covering manufacturers.

Most of the on-site work photos were taken by David McElvenny. Some photos showing product samples were supplied by manufacturers, as acknowledged in the text or photo.

Many TAFE teachers, RTO trainers and industry experts have been involved in the development of this resource. Particular thanks go to the following people for providing learning materials, technical advice and feedback:

Craig Bennett – Hunter Institute of TAFE (NSW)

Steven Dalton – Marleston TAFE

Bruce Ottens – Holmesglen TAFE (Victoria)

Chris Shaw – TasTAFE (Tasmania)

William Tree – ACFIT (NSW)

Mark Willis – Armstrong Flooring



Table of contents

Introduction	1
Section 1 Types of tools	3
Overview	5
General hand tools.....	6
Subfloor preparation	8
Carpet installation	12
Resilient installation	14
Timber installation.....	17
Storage and maintenance.....	19
Assignment 1	21
Section 2 Power sources.....	23
Overview	25
Electricity	26
Compressed air.....	30
Other power sources.....	34
Assignment 2	36
Section 3 Safe operating procedures	37
Overview	39
General safety.....	40
Drill operation.....	42
Jigsaw operation	44
Planer operation.....	45
Circular saw operation	47

Nail gun operation.....	49
Heat welder operation.....	51
Heat bond iron operation	53
Assignment 3.....	54
Practical demonstrations	55

Introduction

Hand-held tools are like extensions to your own body.

They allow you to 'feel' the material you're working with and monitor the performance of the tool through sensations such as resistance to movement, changes in smoothness, and the pull in one direction or another.

This unit will provide you with an overview of the hand and power tools commonly used by floor layers, and the safe operating procedures that apply to using power tools.



We won't go into detail on the techniques for using hand tools such as utility knives, trowels, rollers and scribing tools. These topics are covered in the units that deal directly with installation methods for particular types of flooring. You'll find all of these units on the Flooring Technology website at: www.intar.com.au

Working through this unit



There are three sections in this unit:

- *Types of tools*
- *Power sources*
- *Safe operating procedures.*

Each section contains an *Overview*, an *Assignment* and *Lessons* which cover the content material.

Assignments

Your trainer may ask you to submit the assignments as part of your assessment evidence for the unit. You will find hard-copy templates for these assignments in the separate Workbook.

Electronic 'Word' templates of the assignments are available on the website for this resource, at: www.intar.com.au

Learning activities

Each of the lessons has a learning activity at the end. The Workbook for this unit contains all of the learning activities together with spaces for written answers.

Again, you will find the learning activities on the website version, together with some interactive 'Just for fun' exercises.

Practical demonstrations

Your final assessment of competency in this unit will include various practical demonstrations. To help you get ready for these assessment activities, see the sample checklist shown in the *Practical demonstrations* section at the back of this Learner guide.

Section 1

Types of tools



Overview

There's a wide variety of hand and power tools used by floor layers, often with different designs for each type of tool.

Sometimes you can get away with using a tool that isn't quite right, but gets the job done anyway.

However, it's always best to make the effort to get the exact tool you need, especially if you're doing a certain job over and over again.

The right tool for the job not only makes it easier and quicker to get the task done properly, it also greatly reduces the chance of something going wrong or someone getting hurt.



In this section, we'll look at the range of hand-held tools commonly used in each sector of the flooring technology industry and provide some basic advice on storage and maintenance procedures.

Completing this section



The assignment for this section will ask you to describe a range of hand tools that you use at work. Have a look at *Assignment 1* on page 21 to see what you'll need to do to complete it.

There are also six lessons in this section:

- *General hand tools*
- *Subfloor preparation*
- *Carpet installation*
- *Resilient installation*
- *Timber installation*
- *Storage and maintenance.*

These lessons will provide you with background information relevant to the assignment.



General hand tools



Some general purpose tools are used in just about all of the trades that involve on-site installations.

Below are the main hand tools that you're likely to have in common with the other building trades, even if you're using them for a different purpose.

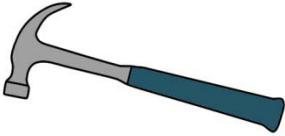
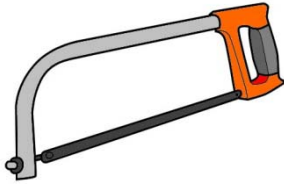
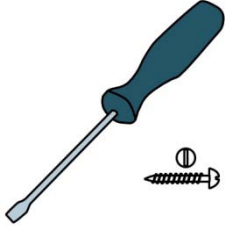
You should take all of these tools with you to the jobsite, whether you're installing carpet, resilient or timber flooring, because each of them could be needed at some stage of the project.

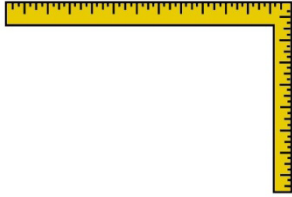

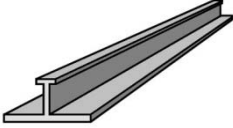
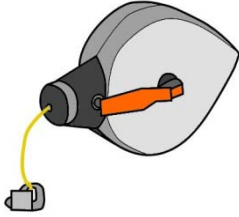
 <p>Claw hammer – for hammering in nails and other fasteners, tapping hardware items into position, withdrawing nails.</p>	 <p>Hacksaw – for cutting metal trims to length and general cutting, shaping and removal of metal or plastic materials.</p>	 <p>Flat head screwdrivers – for inserting and removing screws and other fasteners with a slot head.</p>
 <p>Phillips head screwdrivers – for inserting and removing screws and other fasteners with a Phillips head.</p>	 <p>Cordless drill – for using as a powered Phillips head screwdriver, and for drilling small holes in timber, metal and plastic.</p>	 <p>Builders square – for marking 90 degree angles, checking angles for square and use as a straight edge.</p>

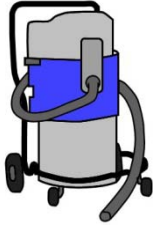
 <p>Straight edge – for drawing straight lines, checking flatness, and guiding a knife when cutting seams and edges.</p>	 <p>Chalk line – for marking set-out lines across a floor.</p>	 <p>Tape measure – for doing measure-ups, checking dimensions, and marking lines and points.</p>
 <p>Hand brush and broom – for sweeping up dust and general rubbish.</p>	 <p>Vacuum cleaner – for vacuuming up dust and fine debris.</p>	

Learning activity



The tools shown above are typical examples of different categories of equipment.

In practice, there are many variations on each of these items – especially the measuring and set-out tools.

What other types of straight edges and squares do you use at work? For example, you might use a T square, bevel, combination square, mitre square or protractor and saw guide.

Go to your workbook and do simple line drawings of your own examples of these set-out tools. Write the name of the tool beside each drawing.

Subfloor preparation

Before you can lay a floor covering, you need to make sure the subfloor is flat, smooth and sound.

Depending on the state of the subfloor and the materials it is made of, you might decide to 'build up' the surface with a cement or wood-based underlay, or 'go down' by removing existing layers of material until you achieve a suitable surface finish.

In some cases, you may have to do both, especially if you're working on an old concrete slab.



That is, you'll probably remove the surface layers with a grinder and then apply a cement-based smoothing or levelling compound with a trowel to form an 'underlayment'.

Below are the main hand and power tools used to prepare concrete and timber subfloors. For more information on how to use these tools, and for details on wheeled machines such as concrete grinders and heavy floor sanders, see the following two units:

- *Subfloor coatings and toppings*
- *Concrete grinding.*

Checking levels







Laser level – for checking levels and flatness in floor surfaces.



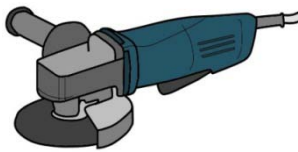
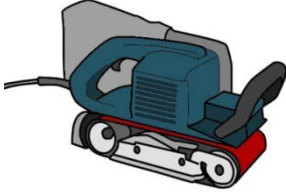
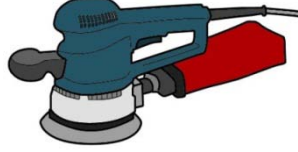
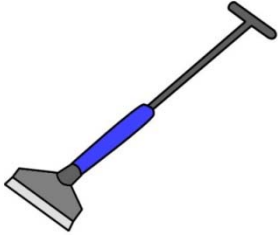
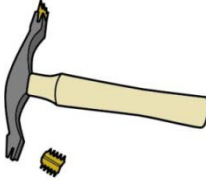
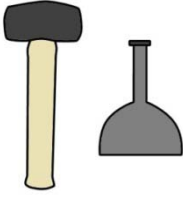

Spirit level – alternative to the laser level.





Removing material

 <p>Angle grinder – for cutting masonry and steel, and for grinding concrete by hand.</p>	 <p>Belt sander – for sanding back timber floor boards and wood-based panels.</p>	 <p>Orbital sander – for use when a belt sander is too awkward, such as around edges and doorways.</p>
 <p>Floor scraper – for removing blobs of cornice plaster and other dags on the floor surface.</p>	 <p>Skutch hammer – for chipping away tiles, mortar and plaster from masonry walls and floors.</p>	 <p>Lump hammer and bolster – for removing blobs of concrete and chipping masonry.</p>
 <p>Pinch bar – for removing floor boards and hard sheet materials that are nailed or glued down.</p>	 <p>Concrete grinder – for grinding concrete with rotating abrasive discs.</p>	 <p>High pressure water – for removing surface contaminants and dust.</p>

Applying moisture membranes

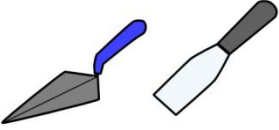
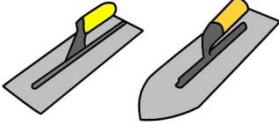
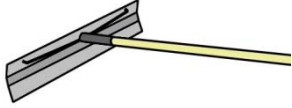

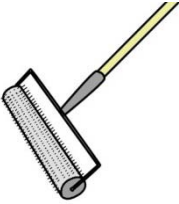
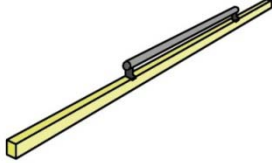
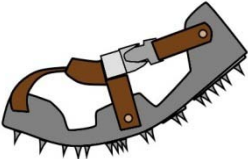
 <p>Paint brush and roller – for applying a liquid moisture membrane to a subfloor.</p>	 <p>Backpack sprayer – alternative method for applying a liquid moisture membrane to a subfloor.</p>
---	---

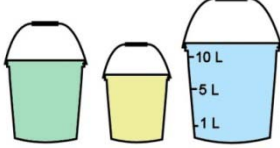
Patching and levelling with cement-based compounds

 <p>Masonry trowel and putty knife – for applying patching compounds to voids in the subfloor.</p>	 <p>Smoothing trowels – for spreading leveling compounds in a kneeling position.</p>	 <p>Thickness spreader – for spreading leveling compounds in a standing position.</p>
 <p>Smoother – used to touch up the underlayment and achieve a feather edge.</p>	 <p>Spiked roller – used to 'de-aerate' (remove air bubbles) from the leveling compound.</p>	 <p>Screed bar – used to spread fresh concrete and achieve a surface ready for trowelling.</p>
 <p>Spiked shoes – for wearing while pouring and spreading wet leveling compound.</p>	 <p>Mixing paddle and heavy-duty drill – for mechanically mixing levelling compounds.</p>	 <p>Mixing and cleaning buckets – for mixing compounds and for cleaning up.</p>

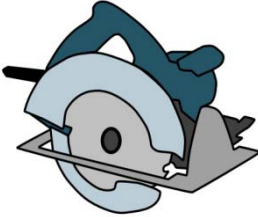
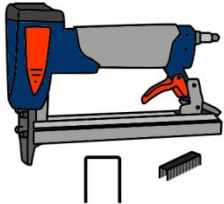
Laying hard underlays

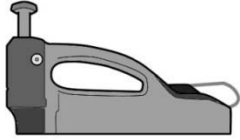
 <p>Jigsaw – for cutting and shaping underlay sheets to fit around doorways and other profiled shapes.</p>	 <p>Circular saw – for cutting straight lines in underlay sheets and for cross-cutting timber.</p>	 <p>Staple gun – for fixing underlay into position on a timber subfloor.</p>
--	--	--

 <p>Spotnailer – used like a staple gun, but driven by a mallet rather than compressed air.</p>	 <p>Handsaw – used when a power saw or jig saw is too awkward or unnecessary.</p>
---	---

Learning activity



Choose one type of subfloor preparation you've been involved in and list all the tools that were used in that job. Go to your workbook and write down the following information:

- type of subfloor and materials used in the substrate (e.g. particleboard flooring on timber floor joists, concrete slab on the ground, etc.)
- hand and power tools used by you and the other members of your team to prepare the substrate up to the stage of laying the floor covering
- brief description of what each tool was used for.

Include all the general hand-held tools that were needed, as well as any specialised tools. Your list may end up including a lot more items than those we've covered in the above two lessons. For example, you may also have used a nail punch, pliers, cold chisel or hand plane.

If you haven't been involved in a subfloor preparation before, choose a particular type of subfloor and list all the tools that you think would be required to prepare it.

Carpet installation

Carpet is a 'textile' floor covering, meaning it is woven from natural or synthetic yarns.



The two most common methods for installing carpet are:

- laying over a cushioned underlay, using a gripper strip around the perimeter to hold the carpet in place
- fixing directly to the floor using an adhesive.

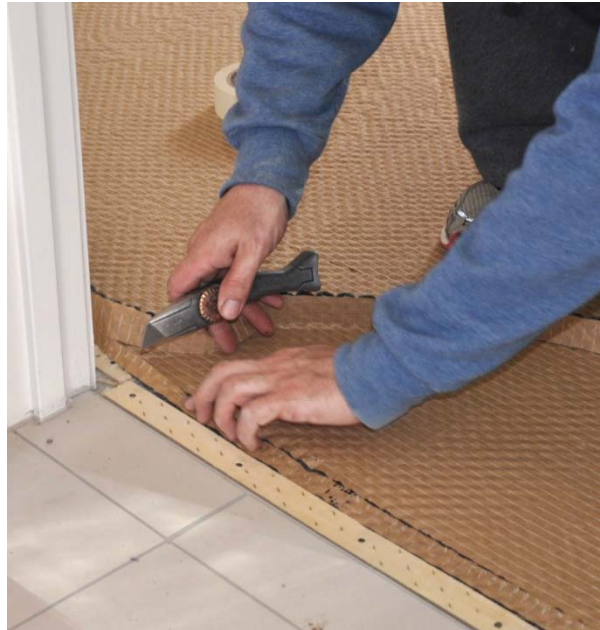
The tools shown below are used in either or both of these installation methods.

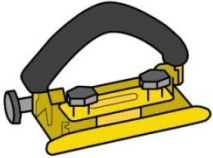
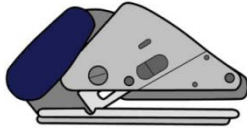
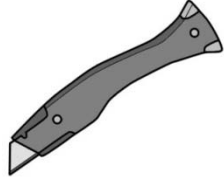
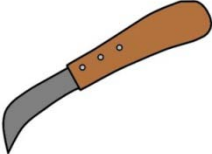

Cutting

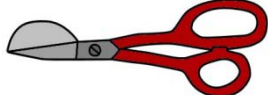
 <p>Carpet wall trimmer – for trimming off excess carpet along the line of the wall.</p>	 <p>Loop pile cutter – for cutting loop pile carpet with a stiff backing.</p>	 <p>Utility knife – for cutting and trimming, especially around doorways and other objects.</p>
 <p>Carpet trimming knife – a more traditional alternative to the utility knife.</p>	 <p>Carpet shears – for cutting and trimming seam edges in woven or knitted carpet.</p>	 <p>Napping shears – similar to carpet shears, but with a 'duckbill' to prevent gouging while trimming.</p>

Seaming

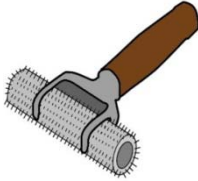
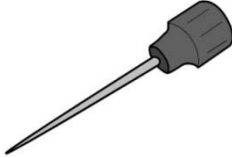
 <p>Heat bond iron – used for thermal bonding of carpet seams.</p>	 <p>Spiked carpet roller – used for rolling out bonded carpet seams.</p>	 <p>Awl – used for scribing lines and picking seams.</p>
--	--	--

Stretching, fitting and general

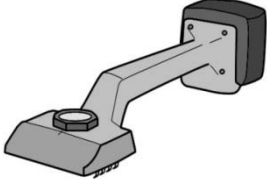
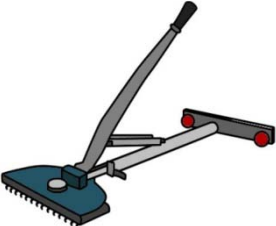
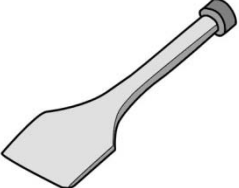
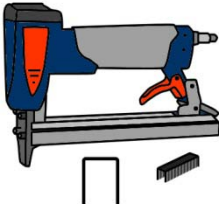
 <p>Knee kicker – used to push the edge of the carpet up to the wall.</p>	 <p>Power stretcher – for stretching the carpet from one wall to another.</p>
 <p>Carpet stair tool – used when laying carpet on stairs to push the carpet into the fold.</p>	 <p>Staple gun – for fixing carpet into position, particularly on stairs, and for fixing hard underlays.</p>

Learning activity



Some carpet layers use other tools in addition to those shown above, such as a sewing needle for hand-sewing seams.

What other tools do you know of that are used to lay carpet? You may have used them yourself, or you may have seen them elsewhere.

Write down the name of each tool and what it's designed for in your workbook.

Resilient installation

Resilient floor coverings include all the products that have the characteristic of resilience, or 'bounce back', such as vinyl, rubber and linoleum.

They are supplied either as sheet products, tiles or planks.



Depending on the end use of the floor, resilient coverings can be loose laid or stuck down with an adhesive.

Set out below are the main tools used to install resilient floor coverings.





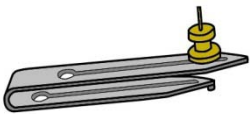
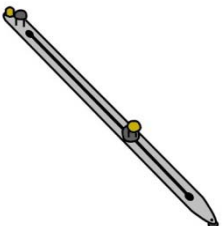

Techniques for using these tools, as well as instructions on how to install the different resilient products, are described in the specialist installation units in this series of Learner guides.

Marking

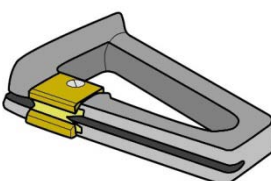
 <p>Recess scribe – for scribing the line of a seam to make sure the two edges match exactly.</p>	 <p>Scribing bar – for scribing the cut edges of a sheet or tile where it fits against a wall or around an object.</p>	 <p>Dividers – an alternative to using a scribing bar when the gap is very small.</p>
---	--	---

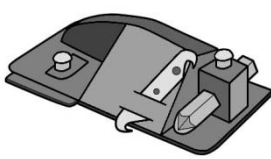
Cutting

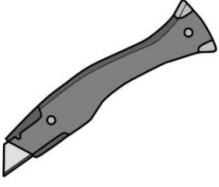

 <p>Edge trimmer – for trimming a straight edge along a sheet.</p>	 <p>Spatula knife – for cutting and trimming the welding rod in a seam.</p>	 <p>Wall trimmer – for trimming off excess material against the wall.</p>
--	---	---



 <p>Utility knife – for cutting and shaping floor coverings, rubber mouldings and other materials.</p>	 <p>Lino knife – for cutting linoleum and other heavy resilient coverings.</p>
--	---

Seaming

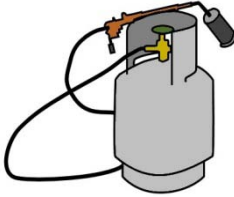
 <p>Hand grooving tool – for cutting a groove along the seam, prior to welding the seam.</p>	 <p>Power groover – a more powerful version of the hand groover.</p>	 <p>Heat welding gun – used to weld seams by melting a welding rod in the groove.</p>
---	---	--

Fitting, sticking down and rolling

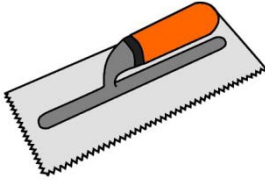
 <p>Hot air gun – for heating and softening vinyl to make it more flexible when fitting it.</p>	 <p>Gas bottle and gun – a more powerful alternative to using a hot air gun.</p>	 <p>Roller – for rolling out the floor covering after laying it in position.</p>
---	--	--

 <p>Rubber mallet – for fitting floor coverings in hard-to-reach areas when a roller is too awkward.</p>	 <p>Serrated trowel – for spreading adhesive on the subfloor prior to laying the floor covering.</p>	 <p>Paint brush and bucket – for applying contact adhesive to skirtings and coved materials.</p>
--	--	--

Learning activity



Choose one type of resilient installation and list all the tools required to lay the floor covering.

State the type of subfloor you will be working on and the flooring product you have chosen.

For each tool you name, briefly describe its purpose.

Timber installation

Timber floors include the following products:

- solid timber tongue and grooved floor boards
- solid timber parquetry blocks
- timber-based engineered products, such as laminated ‘floating floor’ panels.

The methods used to lay timber flooring vary greatly, depending on the type of product being installed and the structure of the subfloor.







For example, tongue and grooved strip flooring is sometimes installed directly onto floor joists to form a structural floor. This type of job is normally done by a carpenter or specialist floor layer. Parquetry is also the domain of specialist installers, because the decorative patterns require special techniques.

Floating floors, however, are commonly installed by general floor layers.

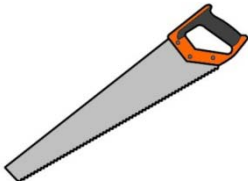
Below are some of the main tools used by timber flooring installers.

General

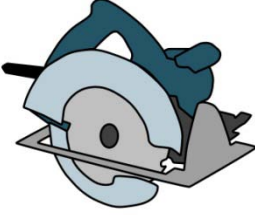
 <p>Hand saw – for cutting timber and board products to length.</p>	 <p>Chisels – for cutting notches and paring back the surface of wood-based products.</p>	 <p>Utility knife – for cutting plastic moisture barriers and other materials.</p>
---	---	--

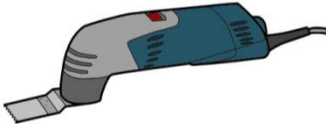
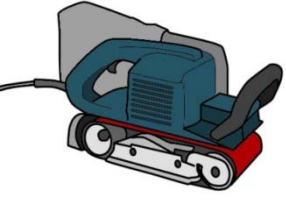
 <p>Drop saw – for cutting floor boards and other timber components to length.</p>	 <p>Electric planer – for reducing the thickness of timber, and planing down the underside of doors.</p>	 <p>Circular saw – for ripping floorboards lengthwise and general cross-cutting.</p>
 <p>Jig saw – for shaping boards and cutting out profiles.</p>	 <p>Multi-tool / undercut saw – for cutting the underside of architraves and skirtings.</p>	 <p>Belt sander – for sanding back timber floor boards and wood-based panels.</p>

Strip flooring

 <p>Nail gun – for fixing timber boards into position.</p>	 <p>Secret nail gun – for fixing 'secret nailed' tongue and grooved boards into position.</p>	 <p>Drum sander / orbital sander – for sanding tongue and grooved strip flooring.</p>
--	---	---

Learning activity



Do you know why laminated flooring products are often called 'floating floors'? Have a look at the photo at the top of this lesson for a clue.

Go to your workbook and write down an explanation of what floating floor means. You may even be able to state a brand name for the product that makes the floor 'float'.

Storage and maintenance

Professional installers need to be able to rely on their tools when they're out at a jobsite.

Missing attachments, blunt blades or malfunctioning parts can be very disruptive to an efficient installation, and very frustrating to the installer – not to mention other team members who might be left waiting.

The good news is that most of these problems are entirely avoidable if you look after your tools and carry spare parts with you.



It's also important to buy high quality tools and replacement parts, so you can have the confidence that they'll do the job you expect of them each time you pick up the tool.

Below are some general suggestions on looking after tools and equipment.

General hints



Don't leave tools lying around on the floor. Put them back in your toolbox or in a designated area when you've finished using them.

This will not only keep them away from dust and sources of damage, it will also reduce the chance of someone else packing them up into their own toolbox.

Protect the cutting edges of saws, chisels, knives and other cutting tools.

Always retract the blade in a utility knife when you're not using it, and put plastic caps on chisel blades or put them in a protective case.



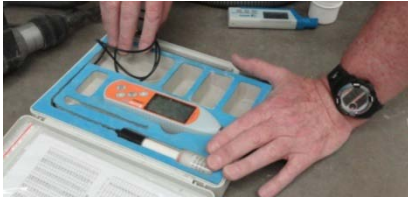

Keep delicate tools in their own bag or carry case.

Sensitive measuring devices and other tools that could be affected by dust or moisture should only be left out while you're actually using them.

Store loose items and spare parts in their own containers.

These may include blades, bolts, screws, pin heads, probes and specialised attachments.



Lubricate moving parts and clean out any excess dust as required.

Don't wait until parts start to seize up or air filters get blocked. The manufacturer's manual for each tool will have a checklist and recommended schedule for carrying out general maintenance procedures.

Put a tag on any tools that are malfunctioning.

This especially applies to power tools. The tag could say 'Do not use' or 'for repair' or something like that. Then take the tool to your supervisor or an authorised maintenance person so they can attend to the problem.

Never put faulty power tools away for someone else to pick up and use – at the very least it will be annoying for them when they find the tool doesn't work, and at worst it could be very dangerous.



Learning activity



Do you have responsibility for carrying out any specific maintenance procedures on the tools you use at work? For example, your job might include being responsible for cleaning out vacuum cleaners and filters, or replacing blunt blades on cutting tools, or doing routine maintenance on machines that need to be oiled or cleaned.

List each tool that you are personally responsible for and briefly state what sort of maintenance procedures you carry out.

Assignment 1

Choose three hand tools you use at work that don't require a power source other than your own muscles. (Note that we will cover power-operated tools separately in Assignment 3.)

For each tool, provide the following information:

1. What type of tool is it?
2. Who is the manufacturer and what is the brand name of the tool?
3. What is its main purpose?
4. What secondary functions does the tool have (if any)? That is, does the tool have any other features, attachments or uses?
5. What personal protective equipment should you wear when you are using the tool (if any)? For example, do you need to wear safety glasses, gloves, dust mask, etc. If you only need to wear PPE for certain types of jobs, state the item of PPE and briefly describe when it would be required.
6. Does the tool have any fragile or delicate parts that need to be protected? If so, how do you protect them, and how do you carry the tool to the jobsite?
7. Does the tool have any parts that are designed to wear out and be replaced on a regular basis? For example, you may need to carry spare blades, cutters, tips, etc. What are these replacement parts, and how do you carry them with you to the jobsite?
8. Do you need to carry any other equipment or maintenance item to the site to keep the tool operational? For example, do you need to have a sharpening stone, oil, grease or other item in your toolbox to keep it working properly?
9. What checks do you need to carry out before you use the tool? These may include safety checks, adjustments, inspections on the sharpness of blades, tightening of screws, etc.
10. What are the main things that can go wrong with the tool? For each problem you state, briefly describe how you would fix it, or whether the problem would mean that the tool must be put in for repair or thrown out.

Section 2

Power sources



Overview

Hand-held tools use a wide range of energy sources.

The most common forms of energy are mains electricity, rechargeable battery, and of course, good old fashioned muscle power.

However, there are times when other power sources are used – generally because you're either using a specialised tool or you're on-site and the mains power hasn't yet been connected.



In this section, we'll look at the main types of energy used to drive hand-held power tools. We won't go into muscle power, because the issues relating to 'manual handling' and physical exertion have already been covered in other units.

Completing this section



The assignment for this section will ask you to compare two tools that are powered by different energy sources, but are designed to do the same job.

Have a look at *Assignment 2* on page 36 to see what you'll need to do to complete it.

There are also three lessons in this section:

- *Electricity*
- *Compressed air*
- *Other power sources.*

These lessons will provide you with background information relevant to the assignment.

Electricity

The two most common sources of electricity for power tools are mains electricity and rechargeable battery.

Note that heavy industrial machines generally run on 415 volt power, also called 'three-phase' power.

However, they use a different type of power plug and socket and are not produced in the hand-held range of power tools.



Mains electricity



Some people refer to mains electricity as '240 volt power', because that's the voltage that comes out of a standard power point.

Standard power points are designed to take two-pin or three-pin plugs. One pin connects to the **active** or live wire. The opposing pin connects to the **neutral** wire, which completes the circuit.

The bottom pin has no role in delivering electricity, but connects the tool to the **earth** wire as a safety mechanism, in case there is a malfunction or 'short circuit'.

Power circuits are always protected either by a fuse or circuit breaker. If the system is overloaded or a fault develops, the fuse is designed to blow, or the circuit breaker to trip, which cuts off the power supply.

There are two main systems of insulation used in power tools:

- **Single insulated tools** use an earth wire which is connected to the metal casing of the tool at one end and the earth pin of the plug at the other end. In the event of a fault that causes a short circuit, the current is able to flow straight to earth without giving the operator an electric shock.
- **Double insulated tools** use two layers of insulation between the internal parts that carry a current and the outer metal parts of the body. For this reason, they are not connected to an earth wire.

Rechargeable battery

As rechargeable batteries continue to improve in performance and power output, an increasing variety of 'cordless' tools are coming onto the market, including jigsaws, circular saws, planers, and even chainsaws.

However, by far the most common cordless power tool is the drill. This is because most drills are smaller and consume less power than the other types of tools, so their rechargeable batteries are lightweight and relatively cheap.



Always remember to pack the battery charger when you take cordless tools to the jobsite. It's also a good idea to take two batteries, so you can leave one on 'charge' while the other is in the tool.

Safety with mains power

Mains power is used everywhere, but that doesn't mean you should take its safety for granted. Every year people are hospitalised as a result of electric shock, and occasionally the shocks prove fatal.



Electrical faults are also responsible for many fires, because the sparks from short circuits or the heat from overloaded wires can ignite flammable substances or materials.

The first rule when using power tools is to make sure the electrical cable is in good condition.

Check that the insulation is sound and there are no exposed wires at the plug end or the other end where it enters the tool.

The second rule is to avoid using electrical tools in wet conditions. If it has been raining, or you're in a wet area, only use the tool if:

- your hands are dry
- the tool is completely dry
- you are wearing rubber soled boots and standing on a dry surface
- electrical leads and connections are clear of damp ground.

Testing and tagging

It is a WorkCover requirement that all power tools used at work are **tested and tagged** every three months by an authorised person. The test is designed to ensure that the tools are safe and not likely to cause a fire or electric shock.

Once a piece of equipment has been tested and passed, the authorised person attaches a tag to it, stating their name or company they work for and the test date.

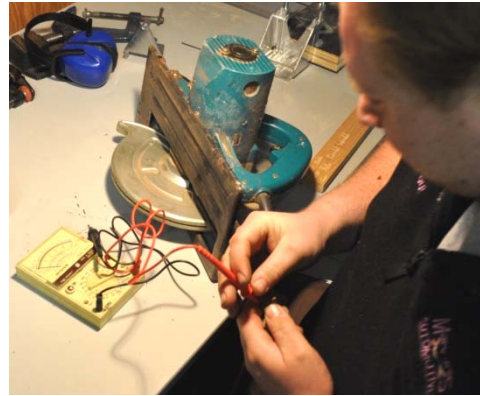

If you pick up a power tool and find that the tag is out of date, make sure you take it straight to the person responsible for getting it tested.

Setting up extension leads

If the power source is not close to the area you're working in, you may need to run an extension lead some distance. Always make the effort to keep extension leads safe, because they can be a serious hazard to your own team as well as other workers on-site if you don't.

Here's some tips on using extension leads safely:

- Fully unwind a long lead before you use it. Leads that are left coiled up can generate a lot of heat when there's a current passing through them.
- Check the plugs at each end to make sure that the wires aren't starting to pull out. If the plugs or lead are not in good condition, tag it and take it straight back to your supervisor for repairs.
- Never pull a plug out of a socket by tugging on the lead. Always hold the body of the plug when you remove it.
- Keep leads clear of wet patches on the ground or floor. This especially applies to any joins in leads.
- As a rule of thumb, use leads rated at a minimum of 10 amps for power tools, and 15 amps or more for large machines.



- Try to keep the lead as short as possible for the job you're doing. The longer a lead is, the higher the voltage drop will be from one end to the other, so the higher its amp rating will need to be.
- Don't drape leads across walkways, access-ways or vehicle paths. If there is no alternative to running a lead across a thoroughfare, make sure the lead is very obvious, and either protect it from vehicle and pedestrian traffic or put it overhead.

Learning activity



Write up a list of the hand-held electric tools you regularly use, naming their brand and power source (mains power or battery).

Also state the size of the tool if you know it. Note that the size is generally expressed in terms of the attachment that does the actual work – such as blade diameter, cutter length or drill bit diameter.

Here are some examples of how the size might be described:

Drill:	10 mm (3/8 inch)	referring to the maximum diameter drill bit that can be put into the chuck
Circular saw:	115 mm (4 1/2 inch)	the diameter of the blade
Electric planer:	75 mm (3 inch)	the width of the cutters

Compressed air

Workshops and factories commonly use compressed air to drive power tools.

For the on-site installer, it's less convenient because you need to take your own compressor with you, which in turn would still have to be powered by an electric, petrol or diesel motor.

However, it is a very useful power source when you're using a gun for nailing, stapling or spraying.

It's also handy when the jobsite doesn't have mains power connected and you already own a petrol-operated compressor.



Tools driven by compressed air are called **pneumatic tools**.

They tend to be more efficient and lighter than equivalent tools powered by mains electricity, because they do away with the need for an electric motor inside the tool.

The compressor itself has a pump which compresses air from the atmosphere.

A receiver, or storage tank, holds the compressed air, and an automatic pressure regulator keeps it at the correct pressure by switching the pump on and off.

If the pressure gets too high, air is released through a safety valve.

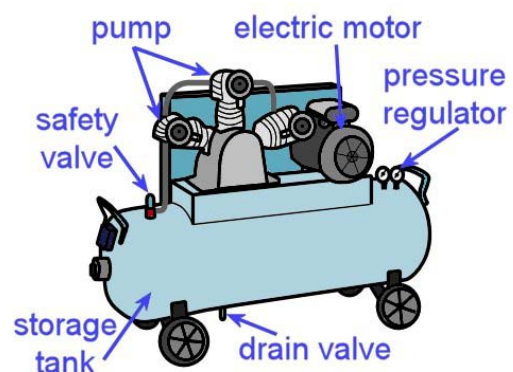

Air supply

The volume of air that a compressor can supply is called **free air delivery**, and is generally measured in terms of litres per minute (L/min). This is what determines how many tools can be run at any one time from the compressor and what types of tools it is suitable for.



Another important specification is the **operating pressure range**. This is measured in kilopascals (kPa) or sometimes pounds per square inch (psi).

Different tools operate best at certain pressures, so the operating pressure needs to be checked and re-adjusted if it's found to be incorrect for a particular tool.

It's a good rule to use the minimum pressure required for the tool to operate properly. This will help the compressor to use less power, and there'll be less wear on the tool.

If you're using a nail or staple gun, it will also reduce the chance of the fasteners countersinking too far and damaging the surface of the material you're firing into.

Routine maintenance for air compressors

Depending on the type of air compressor you're using and the tools you're working with, there will be some routine maintenance procedures that should be followed at certain times. Your supervisor will tell you what your specific tasks are, but here are a few typical examples.

- **Air filters** should be cleaned at regular intervals. If the compressor has a filter bowl, it should be drained each day.
- Some tools need to have **oil drops** added directly to the air intake before the hose is connected each day, to lubricate the moving parts inside.
- **Condensation** that has occurred inside the receiver should be drained at least once a week, or more often depending on the operating conditions and model of compressor. Many workplaces open the drain valve at the end of the week and let the receiver drain over the weekend.
- If the compressor uses a petrol or diesel pump, the **oil level** in the motor will need to be checked regularly.
- The **safety valve** should be checked periodically by lifting the plunger, allowing air to escape, and then making sure that it re-seals properly when it's re-seated.



Special safety precautions

Although compressed air is safer than electricity in some respects, it has other hazards that can be just as dangerous. Below are a few safety guidelines you should follow when using compressed air.

- **Always wear safety glasses** when using compressed air. This includes blowing out tools or cleaning down work areas with an air hose.

The air will cause particles to fly in all directions at high speed.

- **Never point a stream of compressed air** directly at anyone's body, particularly bare skin.

Many people have suffered ruptured ear drums, eye injuries, skin blisters and burst blood vessels from either cleaning themselves down with compressed air, or playing practical jokes with it.

- Make sure you **secure the loose end of an air hose** before turning on the air, to stop it from whipping around when it takes up pressure.



Learning activity



Is there an air compressor in the building where you are right now? You might have it on-site with you, or in the college workshop, or at the warehouse where you're working.

If you don't have a compressor nearby, look up a typical example on the web. Choose a size that you would be likely to use at work.

Answer the following questions in your workbook. You should be able to find the answers on the machine itself or in the specifications listed on the website.

If you get stuck on any questions, ask your trainer or supervisor for more information. They may also be able to show you the manufacturer's manual for the machine.

1. What brand is the compressor?
2. What is the cubic capacity of the receiver?
3. Is the pump diesel, petrol or electric?

4. What is the free air delivery rating (in litres per minute)?
5. What type of air filter does it use?

If you're looking at the compressor right now and it's in operation, also answer the following questions:

6. What operating pressure is it set at?
7. How many hoses branch off it?
8. What types of equipment is it running?

Other power sources

Some specialised tools use power sources other than electricity or compressed air.

This particularly applies to nail guns used on-site, which are sometimes powered by an in-built gas canister or a small explosive powder cartridge.

Let's look at each of these specialised items in turn.



Gas-powered guns

Nail guns powered by gas have a combustion chamber that works like a tiny car engine.

When the chamber behind the piston fills with gas and is ignited by a spark plug, the small explosion pushes the piston forward and drives a nail into the material.

In addition to the gas cylinder needed to supply the gas, these types of guns also carry a rechargeable battery to fire the spark plug.

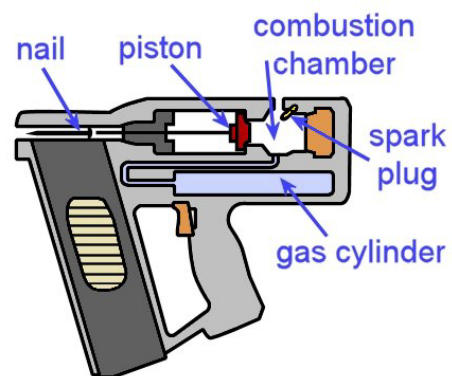

Gas-powered guns have replaced pneumatic guns for many carpenters and other on-site workers, because they don't require an external air compressor. This does away with the problem of having air hoses draped across the work area and causing a trip hazard.

Powder-actuated guns

Powder-actuated (PA) tools are designed to fire fasteners into concrete, steel and other hard materials.

They use the same principle as a firearm, with a small explosive charge placed behind the projectile.

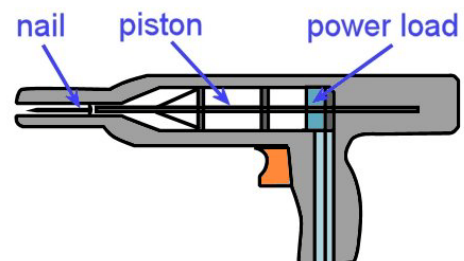

In the case of a PA gun used by a floor layer, the projectile would be a hardened steel nail, or 'drive pin'. Its most likely use would be to fix timber battens or carpet grippers to a concrete floor.

Tradespeople generally call powder-actuated tools by their brand name, which is why you'll often hear them called 'Hilti guns' or 'Ramset guns'.

In the past, they were all manufactured as **high velocity** tools, where the explosive charge acts directly on the fastener.

However, more modern versions use a piston to drive the fastener, allowing a more efficient **low velocity** charge to propel the piston.

The high velocity tools are potentially more hazardous than the low velocity ones, and require greater care when you're using them.

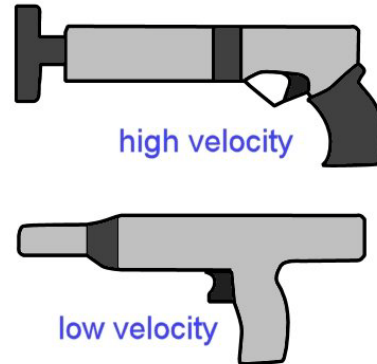

But bear in mind that all powder-actuated guns are potentially dangerous, which is why there are special safety precautions that apply to their use, especially on a jobsite with other workers around. You also need to be properly trained and assessed before you are allowed to use the gun unsupervised.

Learning activity



The following link will take you to a video clip produced by Ramset Australia which describes the difference between high velocity and low velocity powder actuated fasteners. Watch the clip and then answer the questions below.

<http://www.youtube.com/watch?v=MD-yAjSPgwU>

- What is a 'power load'?
- Why is it important to select the correct power load for the material you're fastening into?

To see a more comprehensive 15 minute version of the above video clip, go to the following link:

<http://www.youtube.com/watch?v=2fXgLSHsZNI>

Assignment 2

Choose two power tools from your workplace that both have the same function but are powered by different energy sources. For example, you may have two drills – one running on mains electricity and the other on battery. You might even have a drill that's driven by compressed air.

Answer the following questions:

1. What type of tool are they? State the category of tool your two selections belong to, such as: circular saw, drill, planer, etc.
2. What are the two power sources for these tools? These may include: mains electricity, compressed air, rechargeable battery or gas.
3. Who is the manufacturer (or manufacturers, if they are made by different companies)? That is, what are their brand names?
4. What size is each tool? Describe the size in terms of their drill bit diameter, blade diameter, cutter length, nail length, etc.
5. What are the power ratings? State the power ratings in terms of wattage, operating pressure, etc.
6. What are the main advantages of each tool? List the advantages, particularly in comparison to the other tool you have selected.
7. What are the main disadvantages of each tool? List the main disadvantages, again with particular reference to the other tool.

To get yourself started on the advantages and disadvantages, evaluate the two tools in terms of the following criteria: safety, convenience, portability, overall life expectancy and strength of the tool. Add any other points that you think are relevant.

Section 3

Safe
operating
procedures



Overview

Power tools are generally much faster and more powerful than simple hand tools.

But they have several hazards that don't apply to hand tools, so you need to take extra care when you're using them.

In this section, we'll discuss the safe operating procedures for a range of common power tools.

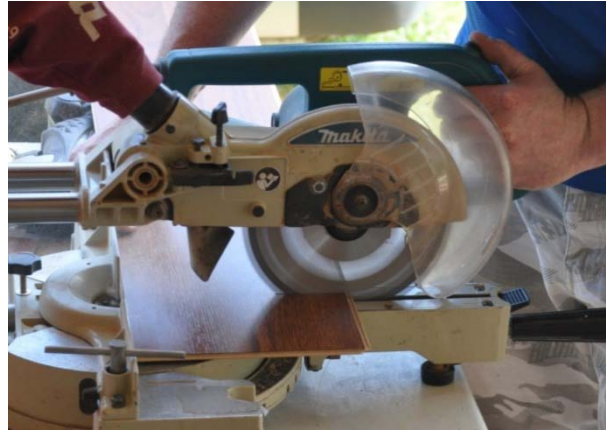

We'll start with a general summary, and then look individually at some of the tools you're likely to use on-site. Remember, though, that every manufacturer will have their own operating procedures for the tools they produce, so you should always consult the operator's manual for detailed advice on how to use a specific tool.

Completing this section



The assignment for this section will ask you to select three power tools that you use at work and describe their characteristics.

Have a look at *Assignment 3* on page 54 to see what you'll need to do to complete it.

There are also eight lessons in this section:

- *General safety*
- *Drill operation*
- *Jigsaw operation*
- *Planer operation*
- *Circular saw operation*
- *Nail gun operation*
- *Heat welder operation*
- *Heat bond iron operation.*

These lessons will provide you with background information relevant to the assignment.

General safety

Set out below are some basic principles for using power tools safely.

Although they can be applied generally to all tools, there are specific references to tools that have a rotary action and are powered by electricity.

This makes these principles particularly applicable to tools such as circular saws, drills and planers.



Basic safety procedures

1. Wear the correct personal protective equipment for the job at hand. This will generally include safety glasses, ear muffs and steel capped boots.

Depending on the job, it might also include a dust mask, gloves and maybe specialised safety gear, such as a full face shield. Remove any loose clothing or jewellery, and tie back long hair.

2. Keep cutting edges sharp. Inspect the saw blade, drill bit or planer cutters before you plug in the tool, and make sure that they are in good condition, properly fitted and sharp.
3. Make sure that the guards are in place and correctly adjusted, and that spring-loaded mechanisms or other moving parts are working normally.
4. Secure the material firmly before you start the job. This could mean using a G-clamp or bench vice or some other clamping system.
5. Always allow the motor to reach normal operating speed before letting the tool come into contact with the job. This helps to avoid the problem of 'kickback', and of overloading the motor.

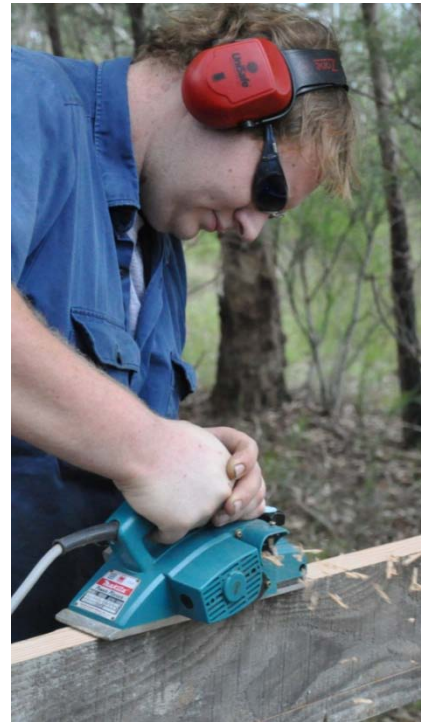

6. Listen to the sound of the motor when you start up the tool and while you're operating it.

If you hear any unusual sounds, stop the tool, unplug it, and look for the problem.

If you can't fix it on the spot, tag the tool and take it to your supervisor or maintenance person for servicing.

7. Keep the work area clear of off-cuts, sawdust build-up and rubbish that might get in the way.

Don't let off-cuts and rubbish build up under your feet. It can pose a serious trip hazard, especially if you're concentrating on the work and not paying attention to where your feet are positioned.

By tidying up as you go, you'll also make the general clean-up at the end of the job much easier. This will help you to sort out which pieces can be recycled or used again and which items need to go straight into the waste bin.



Learning activity



Point 5 above refers to the problem of 'kickback' in power tools. This happens when the blade or cutter is allowed to contact the material to be cut before the motor has had a chance to reach full speed.

What exactly is kickback? See if you can describe it in words.

If you're working with a partner, try to come up with an explanation together. Use your workbook to write down your answer.

Drill operation

Hand-held drills range from small cordless versions to large hammer drills. As a floor layer, there will be times when you'll need both.

A variable-speed cordless drill is best for driving Phillips head screws and drilling small holes in timber and other non-masonry materials.

However, if you're drilling holes in concrete or brick, you'll need to use a hammer drill with a masonry drill bit.

Hammer drills have a 'hammer' and a 'normal' setting. It is possible to buy good quality cordless hammer drills, but in general they're not as powerful as an equivalent-sized 240 volt drill.

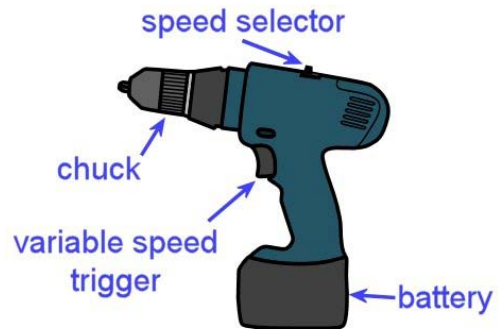

Cordless drill

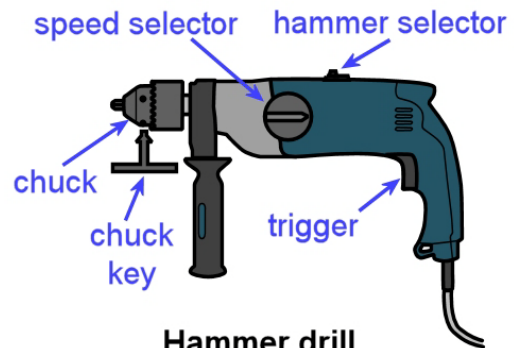

Hammer drill

Basic operating procedure

1. Secure the material that needs to be drilled. Insert the drill bit into the chuck and tighten it. If you're using a chuck key, make sure you take the key out before starting the drill.
2. Push the drill bit into the surface of the material. If the material is metal, it's best to centre-punch a small indentation into the surface first, so that the tip of the drill bit doesn't skid off the mark when it starts to turn.
3. Start up the drill and push down firmly. In general, use slower speeds for hard materials.
4. While you're drilling, pull the drill back periodically to clear the waste material from the hole and drill bit. This will help to stop the drill bit from jamming or overheating.
5. On larger drills use both hands to hold the drill, with one hand on the side handle, to avoid the problem of the drill suddenly flicking back in the opposite direction if the bit gets jammed.

-
6. On deep holes, pay constant attention to the angle you're holding the drill at, so you don't start to change the direction of the hole while you're drilling. Keep the drill bit turning until you withdraw it from the hole.

Learning activity



Different types of drill bits are used for drilling different materials and hole sizes.

See if you can name the type of bit used to drill the following holes. Write your answers in your workbook.

- 6 mm hole in a piece of timber
- 32 mm hole in a sheet of plywood
- 12 mm hole in a concrete slab.

If you're not familiar with the drill bits used for these purposes, ask your trainer or supervisor to show you examples. You can also look them up on the web.

Jigsaw operation

Floor layers use jigsaws when they need to cut a profiled or curved shape in a board product, such as hard underlay sheets, engineered floating floors and solid timber boards.

You can also use them to cut aluminium and plastic trims if you fit the correct blade and use the right setting.

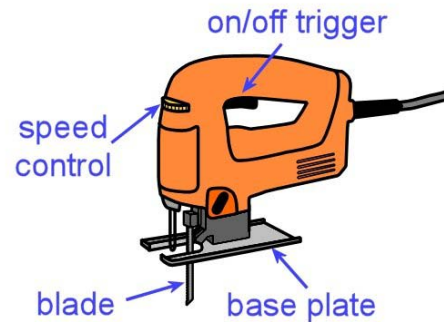

Basic operating procedure

1. Select the correct blade for the material to be cut. Set the saw to the correct speed. In general, higher speeds are used for timber, and lower speeds for metal. Secure the material to be cut.
2. Place the front of the base plate on the material, without the blade touching the work. Check that the base plate is sitting flat on the surface. Start up the saw and let it reach full speed.
3. Begin to cut, keeping the base plate flat on the work at all times. Push the saw smoothly and at a steady pace through the material. Let the saw do the work – don't force the blade through faster than it wants to go.
4. When cutting curves, ease off slightly with pressure and speed to allow the blade to adjust to the changing direction.
5. Finish the cut at full speed and then release the trigger. Allow the blade to stop before putting the saw down.

Learning activity



Jigsaw blades vary in terms of their shape, tooth profile, number of teeth and the type of metal they're made from. The differences are designed to make certain blades more suitable cut cutting particular materials.

Do some research on the different blades available for your own jigsaw, or the one you're using in your training session.

What materials are they designed to cut? Write down the main distinguishing features of the different blades. If you're studying this unit by distance learning, you can also take photos of the blades and match up your descriptions with the photos.

Planer operation

Electric planers are good for taking ridges out of timber floors and refitting doors. But you need to be very careful when you use them.

In floors, always double-check that there are no hidden nails, screws or other hard objects that might hit the cutters. If the cutters strike anything hard while they're turning, it can damage them in an instant.

For doors, the same checks apply. Look out for nail, staples and other metal fasteners. You also need to clamp the door firmly to a bench or saw stool so it doesn't move while you're working.

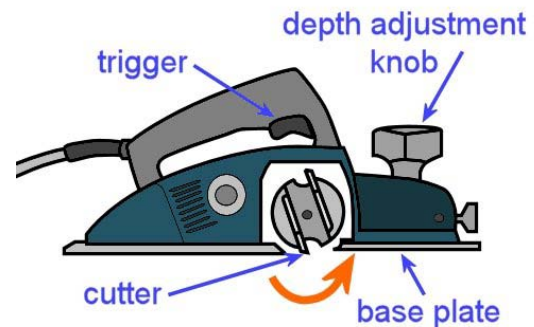

In general, be extremely careful while the planer is running. The cutters are unguarded, and will cut anything that comes into contact with them – timber, floor coverings, clothing, fingers and anything else.

Before you put the planer down, make sure the cutters have stopped turning.

Always disconnect the planer from the power source before clearing out shavings or checking the cutters.

You can either lay it on its side, or put it on a soft material that won't damage the cutters. Remember, the cutters are razor sharp, which makes the edge quite fragile if it is bumped against hard surfaces.

Basic operating procedure

1. Secure the material to be planed so it can't move. Set the cutting depth of the planer by sitting it on the work and adjusting the knob.
2. Position your feet so you're in a comfortable balanced position. Make sure the power lead is out of the way of the planer path. You can put the lead over your shoulder if you think it might get in the way.
3. Rest the front of the base plate on the job and check that it is sitting flat on the surface. Keep the cutters clear of the work – check that they're clear by sliding

the planer forward until you feel the cutters touch the work, and then pulling it back slightly.

4. Start the planer and allow it to reach full speed before commencing the cut.
5. Push the planer smoothly forward with an even motion, in the direction of the grain. Be particularly careful to hold the planer flat against the work at the start and finish of the cut and not let it dip at either end.
6. At the end of each sweep along the material, lift the planer off the work before you take your finger off the trigger.

If you're planing the end grain of timber, it's best to work from both sides to avoid chip-out of the grain. This includes the underside of doors, which often have vertical 'stiles' on each side and a 'bottom rail' in between.

Learning activity



Point 5 above says you should plane in the direction of the grain. Note that this applies to solid timber, such as the tongue and grooved timber floor boards. It's not an issue when you're planing particleboard, plywood, MDF or other materials that don't have a distinctive grain direction.

What would happen if you planed solid timber against the grain? That is, what would the finished surface look like?

Circular saw operation

Hand-held circular saws are generally simply called 'power saws'.

They are used to cross-cut timber, rip timber lengthwise and cut wood-based panel products.

Note that they are only designed to cut in a straight line – if you need to cut a profiled shape, such as around a doorjamb or architrave, you should use a jigsaw.

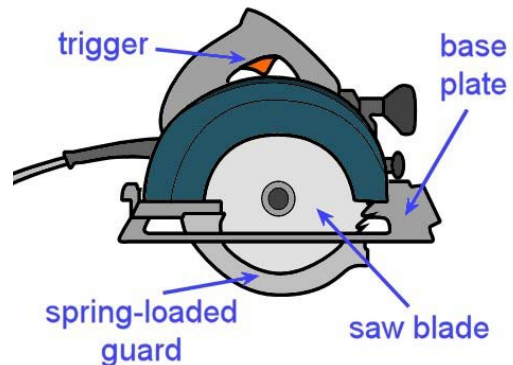

Most power saws run on mains electricity. However, it is possible to buy good quality cordless saws, although they are less powerful than an equivalent-sized 240 volt saw. You can also buy air-operated saws, but they are not as convenient for on-site use.

Like electric planers, circular saws have extra hazards because they're designed to cut at high speed. So many of the same precautions apply, including always being sure that the tool is disconnected from the power source before you check the blade, clear jams or make adjustments.



Unlike an electric planer, you don't need to wait until the saw has stopped turning before you put it down, because the spring-loaded guard will flick back into place when you remove the saw from the work.

But this means you have an additional safety check to carry out – always make sure the guard is moving freely and springing back to its correct position before connecting the saw to the power supply.

Basic operating procedure

1. Secure the material to be cut so it can't move. Draw a line to mark the cut. If the off-cut that will be produced is large or heavy, check that it is well supported so it can't fall or pull away and damage the good piece when you finish the cut.

2. Check the saw blade for damaged or blunt teeth. Check that the spring-loaded guard is working properly. Adjust the saw to the required depth and angle. If you're using a straightedge to guide the saw, clamp it into position.
3. Plug the saw into the power supply. Make sure the power lead is clear of the path of the cut – put it over your shoulder if you think it might get in the way. Position your feet so you're in a comfortable balanced position.
4. Rest the front of the base plate on the material to be cut and check that it is sitting flat on the surface. Keep the blade clear of the work.
5. Start the saw and allow it to reach full speed before commencing the cut. Push the saw smoothly forward with an even motion. Make sure the saw stays straight – don't twist the blade in the cut.
6. Keep the saw straight as you leave the cut and don't release the trigger until the blade is clear of the material. Check that the guard has sprung back into place before placing the saw on the floor.

Learning activity



Point 1 above talks about the importance of securing the material you're about to cut, and making sure any large offcuts will be well-supported before you start cutting.

How would you go about securing the following two pieces of work? Write your answers down in your workbook. You can use a drawing for each one to illustrate your answer if you wish.

1. A long length of solid timber skirting board (say 4.8 m long), to be cut in the middle.
2. A 2400 x 1200 sheet of plywood, to be cut back to 1800 x 1200.

Nail gun operation

Nail guns and staple guns are designed to fire fasteners into timber or wood-based products. The most common power sources are compressed air and gas.

Floor layers often use nail guns to fix carpet gripper to subfloors made of particleboard or plywood sheets.

They also use staple guns to fix carpet to stairs and to fasten hardboard underlay to wood-based subfloors.

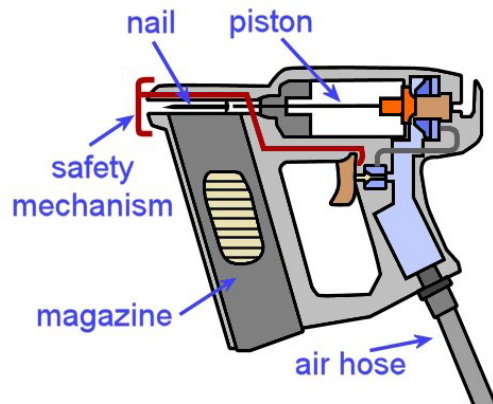

Set out below are the basic procedures for using a pneumatic gun.

Basic operating procedure

1. Make sure the gun is disconnected from the air supply and check that the moving parts and magazine are free from loose particles, dust build-up and anything else that might cause a jam.
2. Load the magazine with nails or staples. Connect the air supply to the tool.
3. Push the nose into the work to allow the safety mechanism to depress.
4. Pull the trigger to fire the gun.

In general, keep the following safety considerations in mind whenever you're using a nail or staple gun:

- Always keep your free hand away from the discharge area while you're firing.
- Don't fire fasteners into knots or unsound timber.
- Don't fire fasteners at a sharp angle or too close to edge of the material.
- Never fire towards yourself or in the direction of other people.
- Always disconnect the gun from the air supply before carrying out maintenance, clearing a jam, or handing the gun to another person.



Learning activity



The basic operating procedure described above refers to a trigger action called 'single shot mode'.

In this action, you need to push the nose into the work to let the safety mechanism depress and then pull the trigger to fire the gun. To fire a second nail, you must go through the whole process again.

Some guns have two operating modes – 'single shot' and 'bump fire'. When the bump fire action is selected, you can keep the trigger depressed and simply bump the nose of the gun onto the work each time you want to fire a nail. Bump fire is handy for jobs where you need to fire many nails in quick succession.

What do you think would be the extra safety problems associated with bump fire mode? How would this affect the way you use the gun, or position yourself before you start firing?

Heat welder operation

Heat welders are used to weld the seams in sheet vinyl floors. This stops dirt, moisture and other substances from getting into the joins.

Before the seam can be welded, the joint must be grooved with a hand or power groover. The depth and width of the groove may vary, depending on the type of flooring product being welded.

Once the groove has been prepared, the welding gun is used to heat the flooring material and welding cable so that they melt and fuse together.

Set out below is a summary of the procedure. Note that welding is a skill that takes some time to master, and there are many issues you need to consider and allow for in order to produce a professional result.

For a more comprehensive discussion on the techniques involved in preparing the groove, welding the seam and dealing with problems, go to the following lessons from the *Commercial vinyl* unit:

- 'Heat welding equipment'
- 'The welding process'
- 'Heat welding problems'.

These lessons also contain links to various video clips produced by flooring manufacturers on how to groove and weld a vinyl floor.

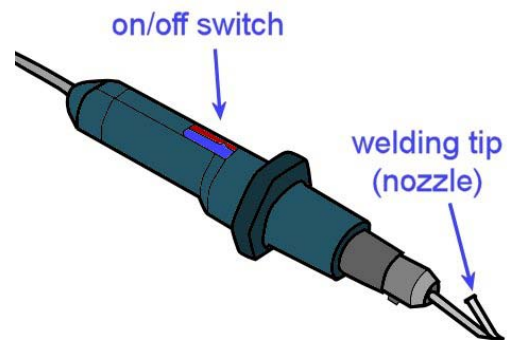

Basic operating procedure

1. Groove out the seam to two-thirds of the depth of the material with a hand groover or turbo groover.
2. Select the correct welding tip and cable for the type of flooring being welded.
3. Fit the tip to the welding gun and turn it on. Let it reach the set operating temperature. Cut the welding cable to length, and thread it through the nozzle.

4. Weld the material, starting at the wall and moving away at a steady speed.
5. Complete the weld and trim off the excess material down to about half a millimetre using a sharp spatula and slider. Do this while the cable is still warm so that it cuts smoothly without gouging. This first cut will also help the cable to cool more quickly.
6. Wait until the material cools, and then trim the cable flush with the floor surface using a spatula angled slightly across the line of the cut.

Learning activity



Heat welders use different sized tips for different floor coverings. The floor covering manufacturer generally specifies what tip size is appropriate for the welded seams on particular products.

Can you name a specific sheet vinyl or linoleum product that you work with and state the recommended tip size for the welded seams?

If you haven't done this sort of work before, or can't remember what tip size you used on previous jobs, do some research and find out what tip size is recommended for a specific product.

Heat bond iron operation

A heat bond iron is used for thermal bonding of carpet seams.

A bonding tape is placed under the seam first, and the iron is then pushed along the seam, melting and spreading the adhesive as it goes.

The tail of the iron is designed to bring the carpet edges together, which allows them to bond as the adhesive cools.

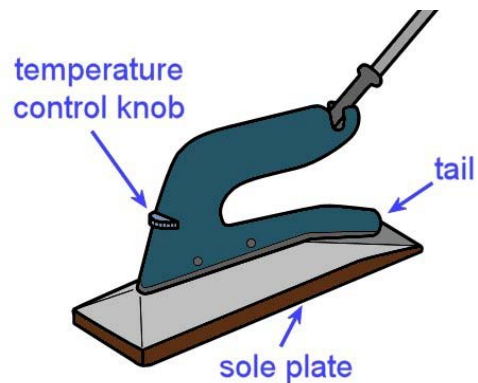

Basic operating procedure

1. Preheat the iron to the temperature recommended for the type of carpet you are seaming.
2. Butt the carpet edges together with a knee kicker, and place the bonding tape under the seam.
3. Melt the end of the tape and hook it on to the carpet gripper.
4. Tuck the seam edges of the carpet under the metal guides at the tail of the iron.
5. Move the iron forward at about one metre per minute. Use a slow, smooth action and avoid stopping and starting.
6. Use your free hand to press the seam edges together at the tail of the iron, and to lift any trapped pile.
7. When the tape has melted, remove the iron and work the seam together by hand. Place the hot iron in the tray whenever you remove it from the seam.
8. While the adhesive is still warm, use a seam roller to push the carpet down into the adhesive to make sure it penetrates the backing.

Learning activity



Carpet manufacturers specify the required temperature for thermal bonded seams. Can you name a carpet product and the recommended temperature setting for the heat bond iron?

If you don't know this information offhand, do some research and find out what the recommended temperature is for a specific product.

Assignment 3

Choose three hand-held power tools you use at work. Do not include either of the tools you selected for Assignment 2. In preference, select tools you will be using for your practical demonstration assessment activities in this unit.

For each tool, answer the following questions:

1. What type of tool is it?
2. Who is the manufacturer and what is the brand name of the tool?
3. What is its main purpose?
4. What personal protective equipment should you wear when you're using the tool? For example, do you need to wear ear muffs, safety glasses, dust mask, etc. If you only need to wear PPE for certain types of jobs, state the item of PPE and briefly describe when it would be required.
5. Specify the attachment or item of hardware on the tool that does the actual work – that is, the drilling, cutting, welding, fastening, heating etc. Preferably, describe the attachments you'll be using for your practical assessment activity, if they are different from the one that's normally fitted to the tool.
6. What checks do you need to carry out before you use the tool? These may include adjustments, calibrations, safety checks, inspections of wear and tear, etc.
7. What routine maintenance procedures are required to keep the tool in good condition? Describe the maintenance procedures, including when they should be carried out, e.g. after each use, weekly, monthly, etc.
8. What are the main problems that would cause you to tag-out the tool and have it discarded or put in for repair? Describe the sorts of things that would make you think the tool was not safe to use. These could relate to unusual sounds, smells, loose parts, damaged parts, etc.

Practical demonstrations

The checklist below sets out the sorts of things your trainer will be looking for when you undertake the practical demonstrations for this unit. Make sure you talk to your trainer or supervisor about any of the details that you don't understand, or aren't ready to demonstrate, before the assessment event is organised. This will give you time to get the hang of the tasks you will need to perform, so that you'll feel more confident when the time comes to be assessed.

When you are able to tick all of the YES boxes below you will be ready to carry out the practical demonstration component of this unit.

General performance evidence	YES
1. Follow all relevant WHS laws and regulations, and company policies and procedures	<input type="checkbox"/>
2. Identify tools and their functions, and select the correct tools for the job	<input type="checkbox"/>
3. Check that tools are operating properly and safely	<input type="checkbox"/>
4. Recognise different sources of power supply	<input type="checkbox"/>
5. Correct faults within level of authority, or take tools to authorised person for repair	<input type="checkbox"/>
6. Select appropriate equipment for holding down or supporting materials	<input type="checkbox"/>
7. Secure material firmly before starting work with hand or power tools	<input type="checkbox"/>
8. Wear appropriate PPE for the job being undertaken	<input type="checkbox"/>
9. Operate tools safely and efficiently, and keep them secure when not in use	<input type="checkbox"/>
10. Store or recycle unused materials	<input type="checkbox"/>
11. Clean and store tools and equipment appropriately	<input type="checkbox"/>
12. Clean up work area and dispose of rubbish properly	<input type="checkbox"/>
13. Accurately complete all required documentation	<input type="checkbox"/>